

DC to DC CONVERTER

SPECIFICATION

Model Number : GP83

Revision : A0

Date : 2008/01/18

Form Factors : ATX

Approval	Check	Prepared

Engineering Change History

Rev. No.	Item	Descriptions of Change		Change Date
		Before	After	
A0			Initial release.	2008/01/18

CONTENTS

	Page
1. Scope -----	4
2. DC Input -----	4
2.1 Input Requirements -----	4
2.2 Efficiency -----	4
3. DC Output -----	4
3.1 Output Power Distribution -----	4
3.2 Output Voltage Regulation -----	4
3.3 Output Ripple and Noise -----	6
3.4 +5VSB Output -----	6
3.5 DC Output -----	6
4. Timing and Signal -----	7
4.1 Signal Timing Drawing -----	7
4.2 Overshoot and Undershoot -----	7
4.3 Power-on Time -----	7
4.4 Rise Time -----	7
4.5 Power Good Signal -----	8
4.6 PS-ON# Signal -----	8
5. Output Protection -----	8
5.1 Over Voltage Protection -----	8
5.2 Short Circuit Protection -----	8
5.3 Over Power Protection -----	9
5.4 No-load Operation -----	9
5.5 Reset After Shutdown -----	9

CONTENTS

	Page
6. Environment -----	9
6.1 Operation -----	9
6.2 Shipping and Storage -----	9
7. Reliability -----	9
7.1 MTBF -----	10
7.2 Burn-in Test-----	10
8. Mechanical Specification -----	9
8.1 Weight -----	9
8.2 Dimension -----	9
8.3 DC Output Connector Type and Pin Assignment -----	9



1. Scope

This specification defines the performances and characteristics of a **160** watts, **5** output level DC to DC converter for use in ITX computer system product.

2. DC Input

2.1 Input Requirements

Parameter	Minimum	Nominal	Maximum	Unit
V _{in}	8		28	VDC
I _{in}			15	A
Ripple & Noise			300	mVp-p

2.2 Efficiency

The converter efficiency should not be less than **90%** at the maximum load of section 3.1 with nominal DC input voltage specified in section 2.1.

3. DC Output

3.1 Output Connector

Output Connector	ATX Power 20 pin (Molex P/N 39-01-2200)
------------------	---

3.2 Maximum Power Characteristics

Output Rail	Current (Max)	Current Peak (<60 seconds)	Regulation
5V	8A	12A	1.5%
3.3V	8A	12A	1.5%
5VSB	1.5A	2A	1.5%
-12V	0.15A	0.2A	5-%
12V	8A* (see below)	9A	2%

Total power = 160 Watts

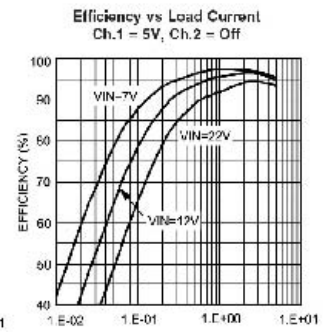
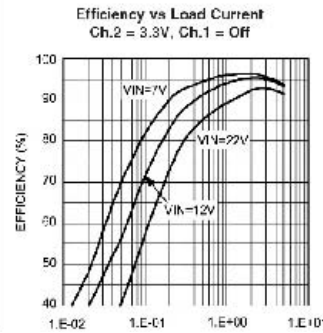
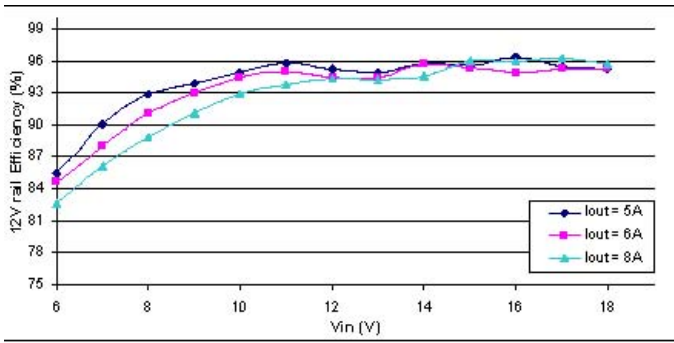

*Units starts failing at ~115 Celsius. Operating at temperatures above 85C / 185F will drastically reduce the MTBF. When operating at high temperatures or fanless operation, must reduce PSU load by 25%.

When operating at 24V or extreme temperatures, de-rate by 25%, ventilation will be required.

12V Rail Output Current

Input (V)	12V rail current	Input (V)	12V rail current
8V	6A	12V	8A
9V	7A	14V	8.5A
10V	8A	14-18V	9A
11V	8A	20-28V	7A

For low input voltage (8-10V) ventilation might be required for peak load

3.3 Output Voltage Regulation

Output	Range	Minimum	Nominal	Maximum	Unit
+12V	±5%	11.40	12.00	12.60	Volts
+5V	±5%	4.75	5.00	5.25	Volts
+3.3V	±5%	3.14	3.30	3.46	Volts
-12V	±10%	-10.8	-12.00	-13.2	Volts
+5VSB	±5%	4.75	5.00	5.25	Volts

3.4 Output Ripple and Noise

- 3.3.1 The output ripple & noise requirements listed in below should be met throughout the load ranges specified in section 3.1 and under all input voltage conditions as specified in section 2.1
- 3.3.2 Ripple and noise are defined as periodic or random signals over frequency band of 10Hz to 20MHz. Measurement shall be made with an oscilloscope with 20MHz bandwidth. Output should be bypass at the connector with a 0.1uF ceramic disk capacitor and a 10uF electrolytic capacitor to simulate system loading.
- 3.3.3 Specification:

Output	Maximum Ripple & Noise (mVp-p)
+12V	120
+5V	50
+3.3V	50
-12V	120
+5VSB	50

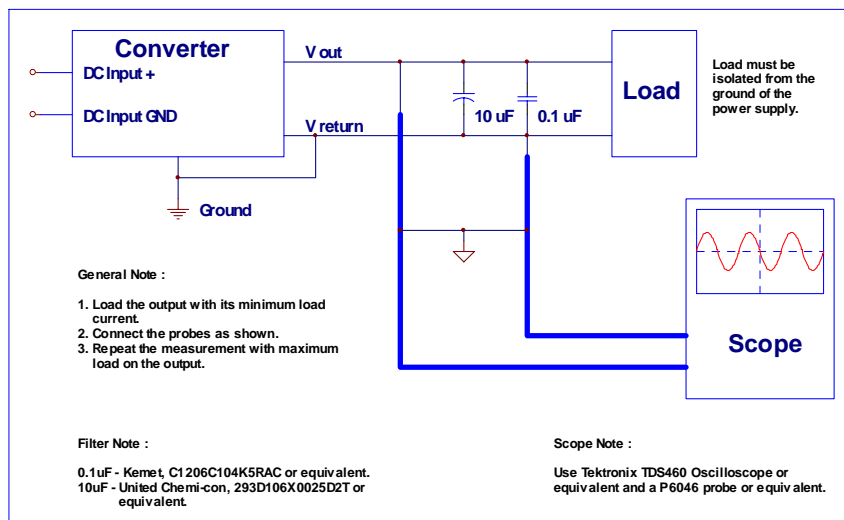

Differential Noise Test Setup

3.5 +5VSB Output

The +5VSB is a standby supply output is active whenever the DC input is present.

3.6 DC Output

This DC output +5VSB is controlled by the DC input, but the other DC output is controlled by the “ PS-ON# “ signal and DC input.

4. Timing and Signal

4.1 Signal Time Drawing

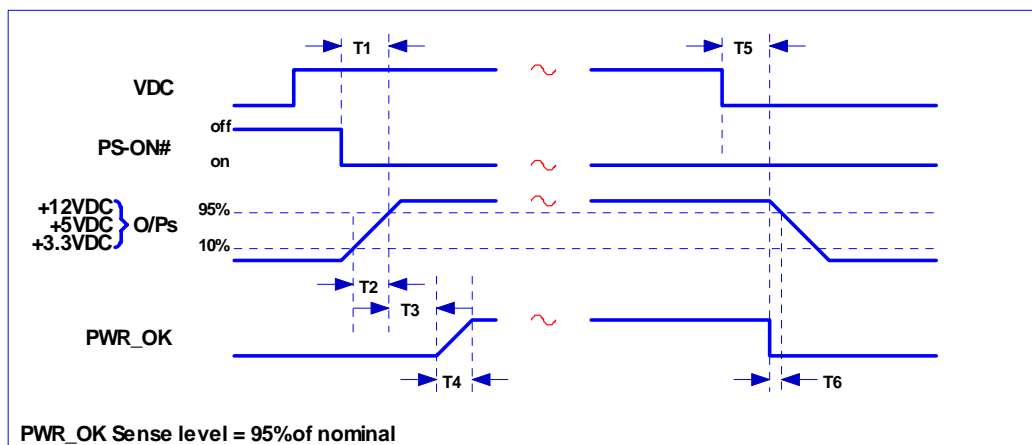

Signal Timing Drawing

4.2 Overshoot and Undershoot

Any overshoot at turn on or undershoot at turn off shall be less than $\pm 10\%$ of the nominal output voltage values.

4.3 Power-on Time

The Power-on time is defined as the time from when PS-ON# is pulled low to when the +12VDC, +5VDC, and +3.3VDC output are within the regulation range specified in section 3.2. The power-on time shall be less than 500ms ($T_1 < 500ms$).

4.4 Rise Time

The output voltage shall rise from 10% of nominal to within the regulation ranges specified in section 3.1 within 0.2ms to 20ms ($0.2ms \leq T_2 \leq 20ms$).



4.5 Power Good Signal

This is a TTL-compatible signal, At power turn on, the power good signal shall have a turn on delay of at least **100ms** , but no greater than **500ms** after +5V output has reached its minimum sense level 4.75V. At power turn off, the power good signal shall go to a down level at least **1ms** before +5V fall below the regulation limits described in section 3.2 ($100ms \leq T_3 \leq 500ms$ and $T_6 \geq 1ms$).

4.6 PS-ON# Signal

PS-ON# is an active-low, TTL-compatible signal. When PS-ON# is pulled to TTL low, the converter should turn on the four main DC output rails: +12VDC, +5VDC, +3.3VDC, and -12VDC. When PS-ON# is pulled to TTL high or open-circuit, the DC output rails should not deliver current. PS-ON# has no effect on +5VSB output, which is always enable whenever the DC input is present.

Logic level : “High ” is 2.0V ~ 5.25V

“Low ” is 0.0V ~ 0.8V

5. Output Protection

5.1 Over Voltage Protection

When the +12VDC, +5Vdc, and +3.3VDC output have over voltage condition, the converter shall provide latch mode over voltage protection as defined in following table.

Output	Minimum	Nominal	Maximum	Unit
+12V	13.4	13.8	15.6	Volts
+5V	5.7	6.1	7.0	Volts
+3.3V	3.7	3.9	4.3	Volts

5.2 Short Circuit Protection

An output short circuit is defined as any output impedance of less than 0.1 ohms. The converter shall shut down and latch off for shorting the +3.3VDC, +5VDC, or +12VDC rails to return or any other rail. Shorts between main output rails and +5Vsb shall not cause any damage to converter. The converter shall either shut down and latch off or fold back for shorting the negative rails. +5Vsb must be capable of being shorted indefinitely, but when the short is removed, the +5Vsb output shall recovery automatically or by cycling PS-ON#. The converter shall be capable of withstanding a continuous short-circuit to the output without damage or overstress to the unit.



5.3 Over Power Protection

The converter can use electronic circuit to limit the output power against exceeding 160W of surge power or protected against excessive power delivery at section 6.1 temperature environment due to short circuit of any output or over total power at any input condition.

5.4 No-load Operation

No damage or hazardous condition should occur with all the DC output connectors disconnected from the load. The converter may latch into the shutdown state.

5.5 Reset After Shutdown

If the converter latches into a shutdown state because of a fault condition on its outputs, the converter shall return to normal operation only after the fault has been removed and PS_ON# has been cycled OFF/ON with a minimum OFF time of two seconds.

6. Power challenges in a Vehicle PC

1) The 5V Standby Problem: when a car PC is off, it still spends the power from 5VSB rail (5V standby) of the power supplies to issue at least a PSON signal. When it is in the suspend mode, it will consume even more power, because the RAM needs to be powered at all times.

Our solution: Gp83 can fix the problem by cutting off the 5VSB rail after a pre-defined amount of time (see jumper chart, HARDOFF). When 5VSB is always active (HARDOFF=Never), GP83 constantly monitors the battery levels. When battery level drops below 11V for more than one minute, Gp83 will shut down and re-activate only when the input voltage is > 11V.

2) Engine Cranks occur in under-voltage and over-voltage situations.

Our solution: Gp83 can operate as low as 8V and as high as 28V while providing strict regulation on all rails along with input voltage clamping and reverse protection.

3) Loud amplifier pops when PC starts if the PC is connected to the car amplifier.

Our solution: Gp83 has an 'anti-thump' control that will keep your amp OFF while the PC starts.

7. Modes of operation

Model :	GP83	Revision :	A0	Page :	9 OF 14
---------	------	------------	----	--------	---------



Gp83 performs several timing routines and takes actions as follows:

- 1) Ignition=OFF. Nothing happens. GP83 is waiting for ignition signals.
- 2) Ignition=ON. GP83 waits for 2 seconds then turns on the 5Vsb rail. After the 4th second, GP83 sends an “ON” signal to the motherboard (through the ON/OFF 2pins switch J8/J9). The motherboard will turn ON and the system should start booting.
- 3) Ignition=ON during driving. Your computer will remain ON.
- 4) 5VSB will still be provided for another “HARDOFF” seconds (see jumper chart). In the event where the shutdown process is longer than “OFFDELAY” (windows gets frozen, etc), power will be shut down hard, turning off all power rails. If “HARDOFF” is set to “NEVER”, the PSU will always provide 5VSB, therefore the PC can also be in the SLEEP mode. During the HARDOFF procedure, the battery levels will be constantly monitored to prevent deep discharge situations.
- 5) Ignition=OFF. GP83 waits for “OFFDELAY” in seconds (see jumper chart on [Page 2](#)) and then turns the motherboard OFF by sending a signal to the motherboard’s ON/OFF switch. Your computer should turn off gracefully (shutdown procedure). During the time, power will still be available for your PC to perform shutdown.
- 6) Ignition = ON again. GP83 will go to step 1.

NOTE:

- 1) When SW circuit as Mode 0 (as the below picture), Gp83 will be in the “dumb PSU mode”,no ignition timing, no HARDOFF.
- 2) Gp83 will send a gratuitous “ON” pulse to the M/B when power is applied for the first time.
- 3) Do not connect J8/J9 to the M/B on/off switch if you don’t want your PC to be started automatically.

Model :	GP83	Revision :	A0	Page :	10 OF 14
---------	------	------------	----	--------	----------

8. GP83 Logic Diagram

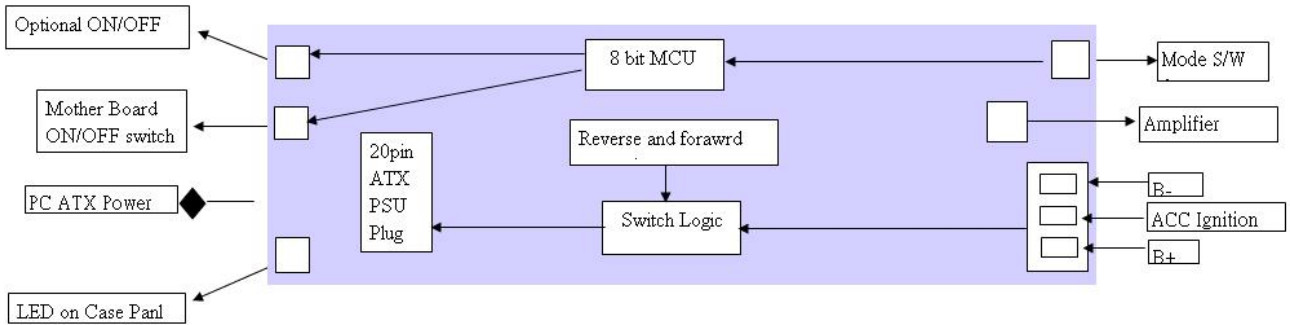

9. GP83 Connection diagram

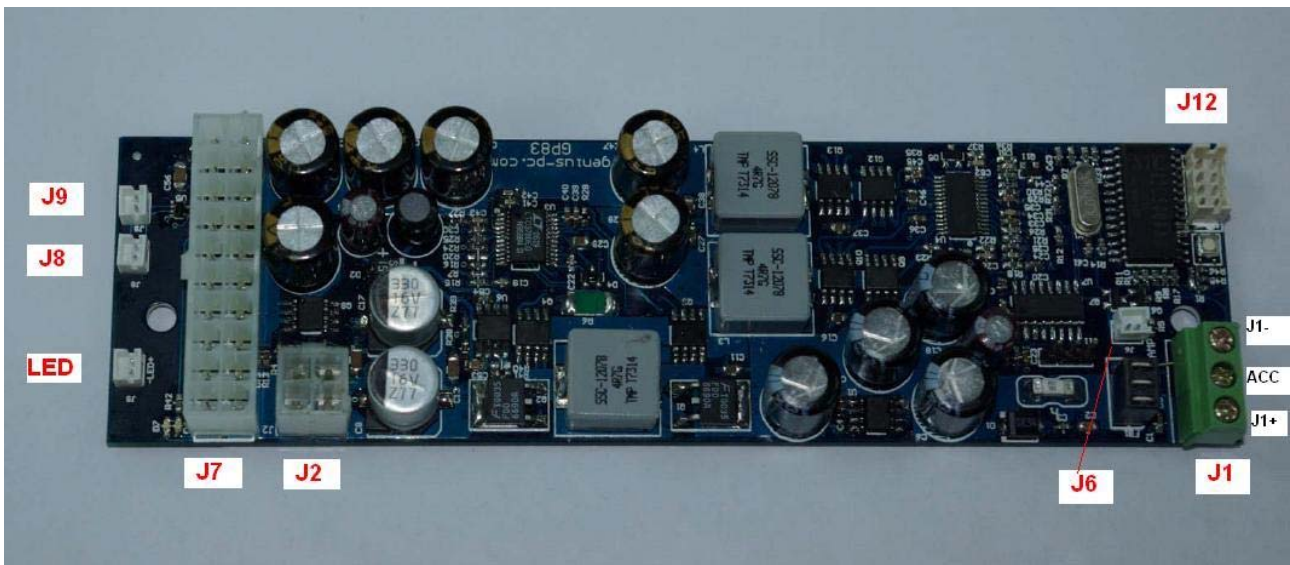

GP83, top view

Power Input Connectors

J1+ Battery + (un-switched battery, positive)

J1ACC Ignition (switched battery, positive. Can test by connecting it to Battery +)



J1- Battery -(negative)

Controls and Settings

J6 Controls amplifier via remote ON/OFF. Left pin is RMT, Right pin is GND

J8 To motherboard ON/OFF switch

J9 To external ON/OFF switch (optional, J8 is in parallel with J9)

J12 To LED Controller (A,B,C) and Modes Circuit Setting Button (D)

SW Modes Circuit Setting

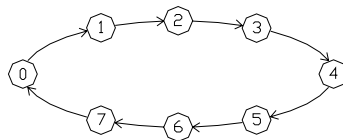

Power Output Connectors

J2 Optional Pentium4 12V power

J7 ATX power connector (to motherboard)

J5 To PC Panel LED (optional)

10. Parameter

Minimum Input Operating. voltage	8V
Maximum input Operating voltage	28V (clamping will occur at 25-27V)
Deep-Discharge shutdown threshold	11.2V
Input current limit (fuse protected)	15A (15A mini-blade fuse)
Max Output Power	160 Watts
Operating temperature	-40 to +85* degrees Celsius
Storage temperature	-55 to +125 degrees Celsius
MTBF	192,000 hrs @ 50C, 96,000 hrs @ 65C
Efficiency (Input 9-16V)	>94%, all rails combined, 50% load.
PCB size	160x45mm
Input connectors	Faston 0.25" terminal

11. Accessories

1) LED Controller



This LED Controller can display the modes status so that you can freely choose the mode you want. Under with the indication meanings:

○ ○ ○	0= (Traditional PSU Mode)
● ○ ○	1= 5Sec / 45Sec
○ ● ○	2= 5Sec / 2Hour (Suggested)
● ● ○	3= 5Sec / Never
○ ○ ●	4= 30Sec / 2hour
● ○ ●	5= 30Sec / Never
○ ● ●	6= 30min / Never, (Taxi Mode)
● ● ●	7= 3Hours / Never, (Taxi Mode)

NOTE: “If HARDOFF is set to “never”, GP83 will automatically shut down when battery voltage is below 11.2V for more than 1 minute in order to prevent ‘deep discharge’ situations.

Mode “0” is regular ATX power supply mode, no power sequencing provided, can be used for non vehicle applications.

Avoid using HARDOFF = Never, can severely discharge your battery if PC. Suggested modes are: 1, 2, and 4.

2) DC-in Header

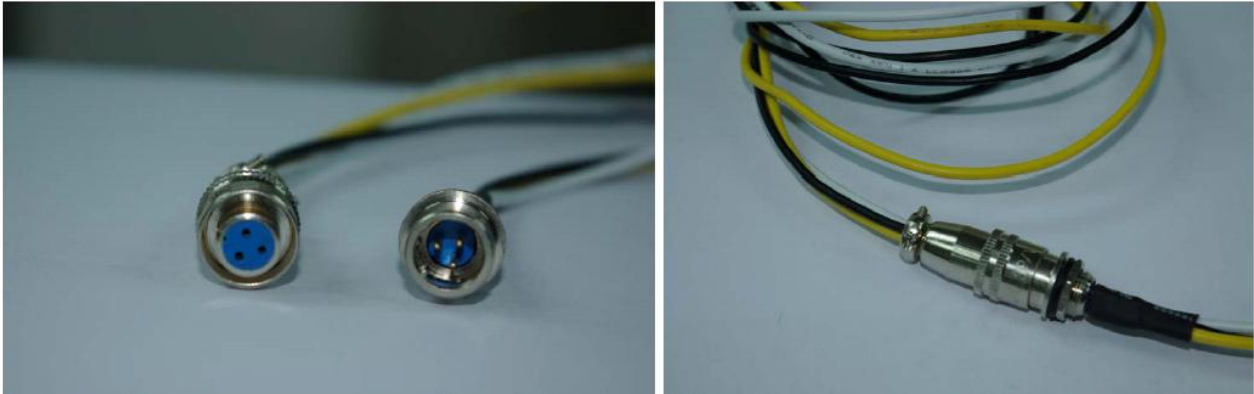

***Standard Car PC Power Supply header**

***Water-proof**

***Protect cables from being broken by folded or drawn out**

***Simply installed and easily unfixed**

***Cable length is 500mm as our standard match. (Optional to be customized).**

Note: when install it to J1, please double check the polarity of the cables and make sure correctly installed.

11.0 Troubleshooting

1) Motherboard is not turning ON.

Check input cables. Measure voltage on the un-switched 12V. You should get about 12V. Measure the un-switched pin(red) while turning the car ON/OFF. You should see 12V (car on) or 0V (car off).

2) Motherboard is not turning ON (cont).

B-1: Check your output cables. Ensure total system power consumption does not exceed the GP83 specifications.

B-2: Make sure that either J8 or J9 is properly connected to the ON/OFF switch of your M/B.